

PART# 600110

2010-2013 Camaro SS 6.2L AR3 Axle Back

Bill Of Materials

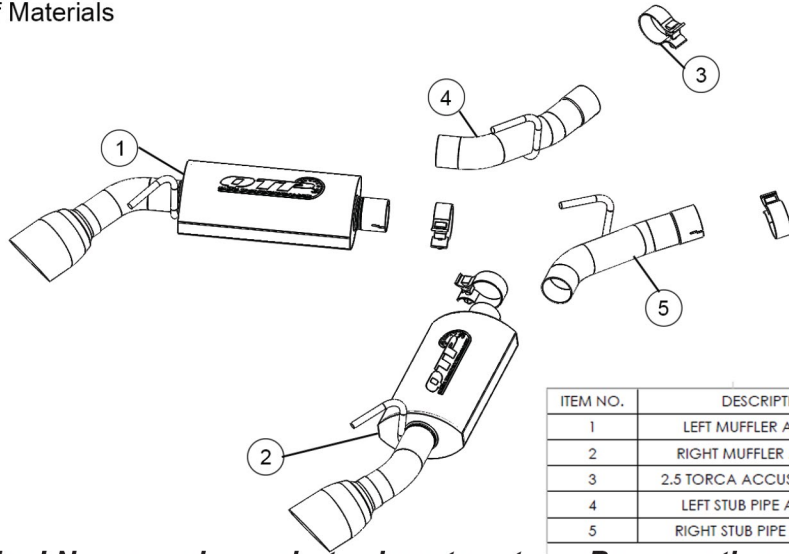

TECHNICAL SUPPORT
973-513-9955
Monday through Friday
9AM-4PM EST

email
tech@quicktimeperformance.com

ITEM NO.	DESCRIPTION	QTY.
1	LEFT MUFFLER ASSEMBLY	1
2	RIGHT MUFFLER ASSEMBLY	1
3	2.5 TORCA ACCUSEAL CLAMP	4
4	LEFT STUB PIPE ASSEMBLY	1
5	RIGHT STUB PIPE ASSEMBLY	1

Tools Required:

15mm Socket Ratchet
Sawzall Tape Measure
Spray lubricant

Caution! Never work on a hot exhaust system. Burns or other serious injuries can result. Always allow the exhaust system to cool before removal. Always consult vehicle manual for proper lifting and support guidelines. Always wear approved safety glasses when working. Serious injury or death can result if safety precautions are not followed.

Removal of factory equipment:

Step 1: Raise and support Vehicle. Using a sawzall, cut the factory exhaust even to the diff housing flange (Figures 1,2.) Square the cut to the tube centerline

Step 2: Spray the rear factory hangers with spray lubricant.

Step 3: Carefully remove each muffler by removing the hangers from the rubber isolators. Once removed deburr the cut end of the remaining factory exhaust with a file. It is critical to remove all burrs as they may keep the new pipes from slipping over the factory exhaust.

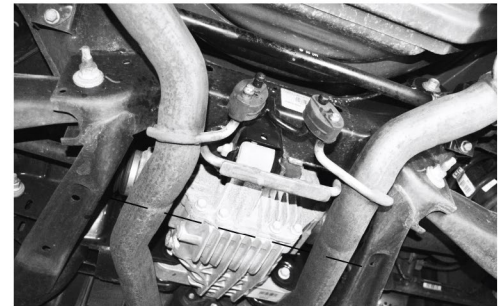

Use seam between diff cover and diff housing as cut line

Figure 1

Installation of new exhaust

Step 4: Slide a 2.5" Torca accuseal clamp onto the end of each stub pipe

Step 5: Slide the expanded end of the stub pipe over the factory exhaust. Spray some lubricant onto the hanger rod and slip it into the factory rubber isolators. Repeat for other side

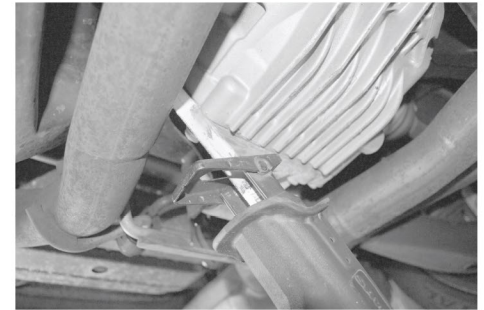

Figure 2

Step 7: Slide a 2.5 Torca accuseal clamp onto the end of each muffler assembly

Step 8: Slide the expanded end of the muffler assembly onto the stub pipe. Spray some lubricant onto the hanger rod and slip it into the factory rubber isolators. Repeat other side.

Step 6: Slide the accuseal clamps into position, center the exhaust tip in the rear valence opening and snug exhaust clamps. Check final position and torque exhaust clamps to 35 ft-lbs. Tighten the muffler clamps first, then the stub pipe clamps. Note: it may be necessary to readjust the exhaust and retighten the clamps after the initial 20 mile drive cycle.

Note: After initial startup a small trace of smoke may be visible from the exhaust, do not be concerned. This is from residual oils left in the tube from the manufacturing process and will dissipate quickly.

Quick Time Performance recommends professional installation on all of our products.